

# Simplified Ball Bearing Selection Process for different Gear Boxes Application with Thermal Analysis

Suraj Prashad Sharma<sup>1</sup>, Priyansh Khandelwal<sup>2</sup>

<sup>1-2</sup>SMEC, Vellore Institute of Technology, Vellore, Tamil Nadu, India

**Abstract** - Providing contact with various combinations of rotating and stationary elements, ball bearings are an essential part of all mechanics and enable simple movement of mechanisms. A ball bearing's main functions are to support radial and axial loads and lessen rotational friction. The temperature inside a bearing rises as a result of friction. The mechanism may fail as a result of the tremendous thermal stress that this heat can produce. Additionally, given ball bearings are typically made of stainless steel, which suggests that they are heavy, it is improper to use heavy bearings in machines that have not been thermally analyzed and selected. The current work seeks to give a streamlined numerical solution to reduce the choice of ball bearings, followed by a thermal analysis to determine the bearing that is most appropriate. The findings of this paper can be utilized by the engineering students participating in several dynamic events across the globe, like mBaja, eBaja, ESI, student formula racing teams, ATVs. SOLIDWORKS is utilized for 3D modeling, and ANSYS is used for thermal analysis. The study is explained using the steering gearbox of an off-road racing car as an example; the method may be utilized with any type of gearbox.

**Key Words:** Ball Bearing, Thermal Analysis, SOLIDWORKS, ANSYS, Steering gear box.

## 1. INTRODUCTION

Bearing is a mechanical component that allows relative motion between 2 components with less friction. Bearings can be classified in two types based on the kind of friction between the bearing surface and shaft; first is Rolling contact and second is Sliding contact bearing. In rolling contact bearings, rolling components like rollers or balls are added between the surfaces which perform relative motion, thereby replacing the sliding friction by rolling friction. This is the reason they are also referred as Antifriction bearings or ball bearings because the coefficient of friction in rolling motion is less than that in sliding friction.

The load applied on bearing can be radial, axial or combined axial and radial which is the most applied load. Ball bearings are generally designed for radial load, though they can withstand axial load to some extent as well. This is the reason to use them in a Gearbox. Gearboxes are designed for transmitting large torque by decreasing the high input speed to the desired output speed. Thus, it is required to increase

the efficiency of gearboxes, which can be achieved by optimizing its designs. This can be done by using the bearings which would not fail and survive for a long period of time. Hence it is very necessary to understand the designing criteria for all the types of bearings that are used in a gearbox. Various kinds of bearings are available and each one of them have a specific load bearing capacity which should be cleared and their applications should also be known before installing them. Even within gearbox different types of bearings are used for a specific purpose and distinct working conditions, hence they require different designs.

Apart from bearing specifications, the gear shafts arrangement and lubrication system is also used to decide the requirements of design and selection of bearing and this is the most challenging part to apply all the information and manufacture the relevant bearing. The bearing can fail in primarily two ways. The first happens when the axial load and gear separating forces are not enough to manage the load on bearing which is required for maintaining the rolling contact. The second way of failure can be due to high thermal stress which arises due to the friction between the shaft and the bearing surface. Therefore, this paper focuses on providing a solution to this problem by reducing the choice of ball bearing by numerical analysis and further by thermal analysis the optimum bearing is determined.

## 2. METHODOLOGY

Ball bearings are chosen through a trial-and-error process in which the inner or outer diameter is initially established based on the demand and the available possibilities are investigated. Using a simplified approach to find the bearing and making a 3D model using the provided pinion data from reference [1]. Two bearings are used to assemble it into the gear box and ensure smooth movement; the lower portion bearing is designated as B1 and the outer portion bearing as B2.

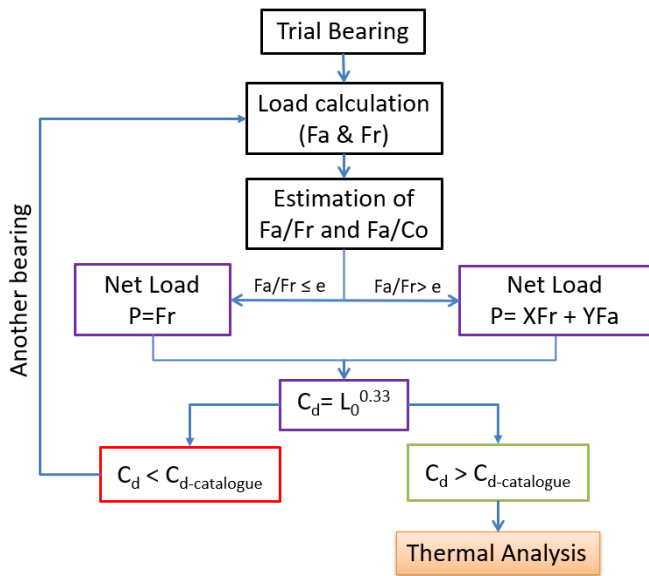

Figure 1 - Process flow chart.

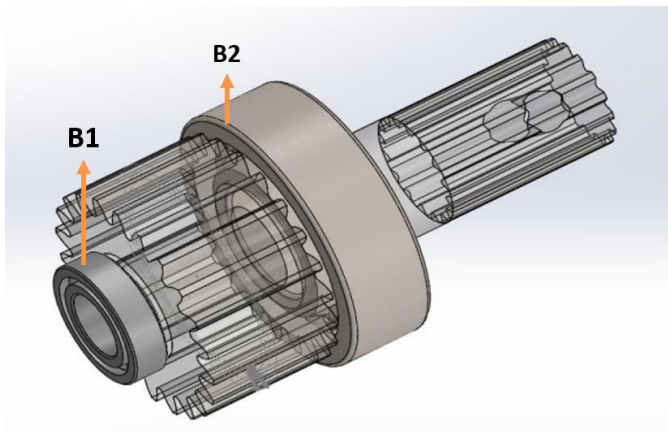

Figure 2 - Position and 3D model of bearings.

### 3. TRIAL BEARING SELECTION

In this case, the inner diameter is fixed by looking through the catalogue and selecting a ball bearing to begin the analysis process.

Table 1 - Bearing data obtained from catalogue.

Sno.	Parameter	Bearing (B1)	Bearing (B2)
1	Inner Diameter	10 mm	17 mm
2	Outer Diameter	26 mm	40 mm
3	Thickness	8 mm	12 mm
4	Static Load Capacity	1960 N	4750 N
5	Dynamic Load Capacity	4950 N	9560 N

### 4. LOAD CALCULATION

According to the reference [1], the torque acting at the pinion is 46.74 Nm, assuming an increased value for safety

margins and presuming the acting torque on the pinion is 50 Nm, which is equivalent to 50000 Nmm.

The net load on the pinion can be calculated using equation 1, where T represents the number of teeth and M represents the gear module, and the values are 33 and 1.5, respectively. Furthermore, axial and radial loads can be calculated using equations 2 and 3. The pressure angle of the pinion gear is P, which is assumed to be 20°.

$$Net\ Load\ (F) = \frac{2 * Torque}{T * M} \tag{1}$$

$$F = 3030.3\ N$$

$$Axial\ Load\ (Fa) = \frac{F * \tan P}{2} \tag{2}$$

$$Fa = 550\ N\ (approximately)$$

$$Radial\ Load\ (Fr) = \frac{F}{2} \tag{3}$$

$$Fr = 1515.15\ N$$

Because we have two bearings, the load will be distributed evenly between them. However, for the sake of analysis, let's use full load for both bearings, which increases safety of factor.

Table 2 - Multiplying factors (X,Y).

Fa/Cs	(Fa/Fr) ≤ e		(Fa/Fr) > e		e
	X	Y	X	Y	
0.025	1	0	0.56	2	0.22
0.040	1	0	0.56	1.8	0.24
0.070	1	0	0.56	1.6	0.27
0.130	1	0	0.56	1.4	0.31
0.250	1	0	0.56	1.2	0.37
0.500	1	0	0.56	1	0.44

#### 4.1 B1 Load Study:

Ratio of axial load with radial load and static load capacity is calculated in equation 4 and equation 5 which is solved below.

$$\frac{Fa}{Cs} = \frac{550}{1960} = 0.28 \tag{4}$$

$$\frac{Fa}{Fr} = \frac{550}{1515.15} = 0.36 < e \tag{5}$$

Fa/Cs is 0.28, in table 2 it is between 0.25 and 0.50, and 'e' is between 0.37 and 0.44, indicating that Fa/Fr is less than 'e'.

As a result, in the following equation 6  $(X,Y) = (1,0)$ , and the net load can be calculated.

$$Net\ Load\ (P) = XF_r + YF_a \quad \dots\dots\dots(6)$$

$$P = Fr = 1515.15\ N$$

**4.2 B2 Load study:**

We can calculate B2 in the same way that we calculated B1. The load ratios are calculated in equations 7 and 8 below.

$$\frac{F_a}{C_s} = \frac{550}{4750} = 0.11 \quad \dots\dots\dots(7)$$

$$\frac{F_a}{F_r} = \frac{550}{1515.15} = 0.36 > e \quad \dots\dots\dots(8)$$

Table 2 clearly shows that for  $F_a/C_s = 0.11$ , 'e' is in the range of 0.27 to 0.31, implying that  $F_a/F_r = 0.36$  is greater than 'e'. The table clearly shows that X is 0.56, and Y can be calculated as the average of 1.6 and 1.4, which is 1.5. Hence net load can be calculated by substituting  $(X,Y)$  in equation 6. Which is solved below:

$$Net\ Load\ (P) = XF_r + YF_a$$

$$P = 0.56*1515.15 + 1.5*550$$

$$P = 1673.5\ N\ (approximately)$$

**5. LIFE AND DYNAMICS CAPACITY STUDY**

**5.1 B1 Life Calculation and Dynamic load capacity calculation**

Given the engineering student competitions such as BAJA, ATVC, and ESI, we do not require a longer life for our bearing, so we will assume a working life (L) of at least 10,000 hours.

Working revolutions (Lo) and Dynamics Load capacity (Cd) can now be calculated using equations 9 and assuming the steering wheel revolution speed (n) is around 60 rpm.

$$L_o = \frac{60 * n * L}{1000000} \quad \dots\dots\dots(9)$$

$$L_o = (60*60*10000)/1000000$$

$$L_o = 36\ million\ revolutions$$

$$C_d = P * (L_o^{0.33}) \quad \dots\dots\dots(10)$$

$$C_d = 1515.15*(36^{0.33})$$

$$C_d = 4943.5\ N$$

Calculated dynamics load (Cd) is 4943.5 N from equation 10 and is less than 4950 N (Dynamic load capacity limit as per table 1) hence B1 is safe to use.

**4.3 B2 Life Calculation and Dynamic load capacity calculation**

Similarly, life and dynamics capacity of B2 can be calculated.

$$L_o = \frac{60 * n * L}{1000000}$$

$$L_o = (60*60*10000)/1000000$$

$$L_o = 36\ million\ revolutions$$

$$C_d = P * (L_o^{0.33})$$

$$C_d = 1673.5*(36^{0.33})$$

$$C_d = 5460.16\ N$$

Calculated dynamics load (Cd) is 5460.16 N which is less than 9560 N (Dynamic load capacity limit as per table 1) hence B2 is also safe to use.

**6. THERMAL ANALYSIS:**

For conducting the thermal-stress analysis, Ansys Workbench provides a very flexible environment. By creating the geometry in the first physical environment, and using it with any following coupled environments, the geometry is kept constant. For our case, we will create the geometry in the Thermal Environment, where the thermal effects will be applied.

The friction coefficient for rolling bearings is expressed by formulae, below:

$$\mu = \frac{2M}{P * D} \quad \dots\dots\dots(11)$$

In the above equation 11,  $\mu$  represents friction coefficient, M is friction moment in Nmm, P is net load in N and D represents bearing bore in mm.

Here we required dynamic friction coefficient of bearing, taken from catalogue and is around  $1*10^{-3}$  to  $1.5*10^{-3}$ .

Almost all friction loss in a bearing is transformed into heat within the bearing itself and causes the temperature of the bearing to rise. The amount of thermal generation caused by the friction moment can be calculated using equation 12.

$$Q = 0.105 * 10^{-6} * M * n \quad \dots\dots\dots(12)$$

Here, Q = Thermal value in kW, M = Friction moment in Nmm and n = revolution speed.

Utilizing the above equations, we can calculate the input for the thermal analysis.

### 6.1 Thermal Study of bearing B1

We can approximate  $M=9$  Nmm for  $P=1500$  using equation 11, and  $Q=0.0567$  N using  $n=60$  rpm using equation 12. Using these values as input in ANSYS results can be generated.

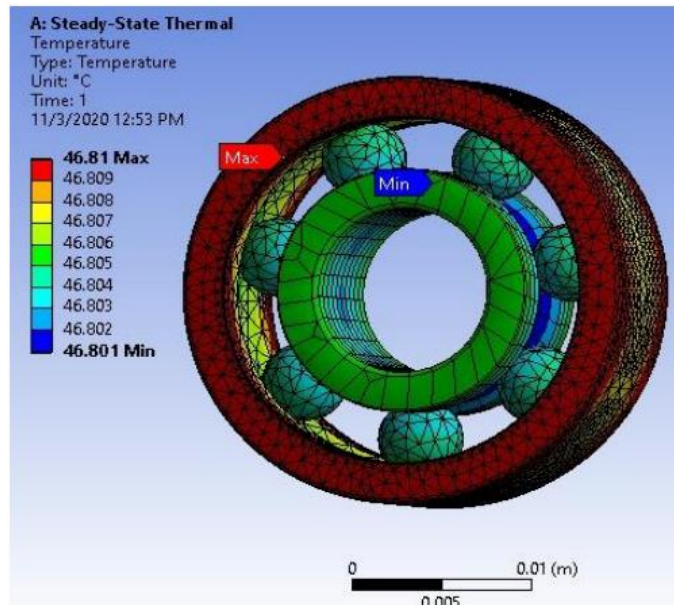

Figure 3 - Temperature variation in bearing B1.

Here maximum temperature reached is  $46.81^{\circ}\text{C}$  which is in operating zone as per catalogue.

### 6.1 Thermal Study of bearing B2

Similar to thermal study of bearing B1, we can approximate  $M = 16$  Nmm for  $P=1600$  using equation 11, and  $Q=0.1$  N using  $n=60$  rpm using equation 12. Using these values as input in ANSYS results can be generated.

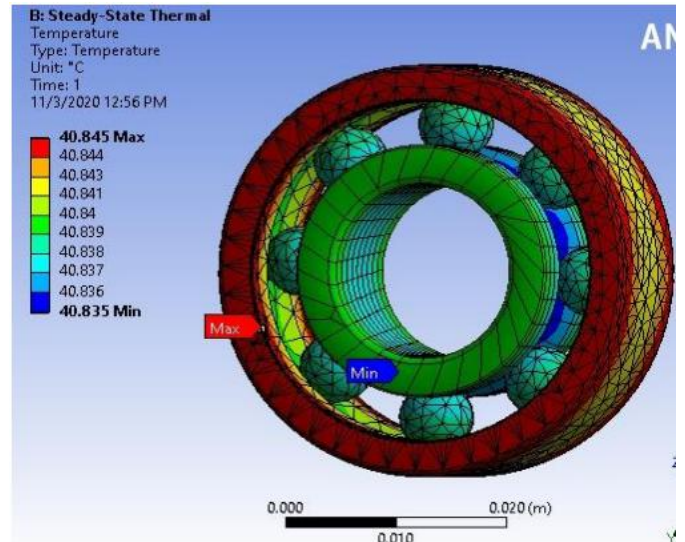

Figure 4 - Temperature variation of bearing B2.

## 3. CONCLUSIONS

Selection of ball bearing is simplified in this analytical study by the help of thermal analysis and mathematical calculations. In this study, application of ball bearing in a steering gearbox is shown as an example. A mathematical model with thermal analysis is presented in this study to understand whether the selected ball bearing would withstand the higher temperature during its working in the steering gearbox. The results obtained in this study could be utilized in making off-road racing ATV, particularly engineering student competition.

## REFERENCES

- [1] Suraj Prashad Sharma and Gedala Udit Narayana, "Simplified Numerical Approach for Steering System Design Parameter Selection for Off-Road Racing", Volume: 09 Issue: 06, Jun 2022, IRJET.
- [2] V B Bhandari, "Design of Machine Elements", Third Edition, The McGraw Hill Companies.
- [3] Ambepasad.S.Kushwaha, Atul B Wankhade, Dinesh E Mahajan, Darshan K Thakur, "Analysis of the Ball Bearing considering the Thermal (Temperature) and Friction Effects", IJERA.
- [4] Viramgama Parth D, "Analysis of Single Row Deep Groove Ball Bearing", Vol. 3 Issue 5, May – 2014, IJERT.

## AUTHOR BIOGRAPHIES



Suraj Prashad Sharma, Automotive Eng, from VIT-University, Vellore, India. BAJA SAE India 2021, 2022 and ESI Pune 2020 participant from Team Kshatriya. Research and study sector – Vehicle Dynamics & Kinematics, Mathematical modelling and analysis.

E-mail - [surajprashadsharma2000@gmail.com](mailto:surajprashadsharma2000@gmail.com)

LinkedIn - <https://www.linkedin.com/in/suraj-sharma-698b391a5/>



Priyansh Khandelwal, B.tech in Mechanical Engineering from VIT University, Vellore, India. Research and study sector- Manufacturing Engineering, Product Development, Design analysis, Materials Technology and Welding Technologies and strategi.

E-mail - [priyansh14kh@gmail.com](mailto:priyansh14kh@gmail.com)

LinkedIn - <https://www.linkedin.com/in/priyansh-khandelwal-a68319184>